

THE INFORMATION CONTAINED IN THIS DRAWING IS THE SOLE PROPERTY OF DANA MOLDED PRODUCTS, INC. ANY REPRODUCTION IN PART OR WHOLE WITHOUT THE WRITTEN PERMISSION OF DANA MOLDED PRODUCTS, INC. IS PROHIBITED. IT IS THE RESPONSIBILITY OF THE CUSTOMER TO DETERMINE THE SUITABILITY OF THIS DESIGN FOR ITS INTENDED PURPOSE.

2	1
PART NUMBER	DIMENSION "A"
DM 38M-0107-XXX	36.5
DM 38M-DBJ-0107-XXX	32.3

D

C

B

A

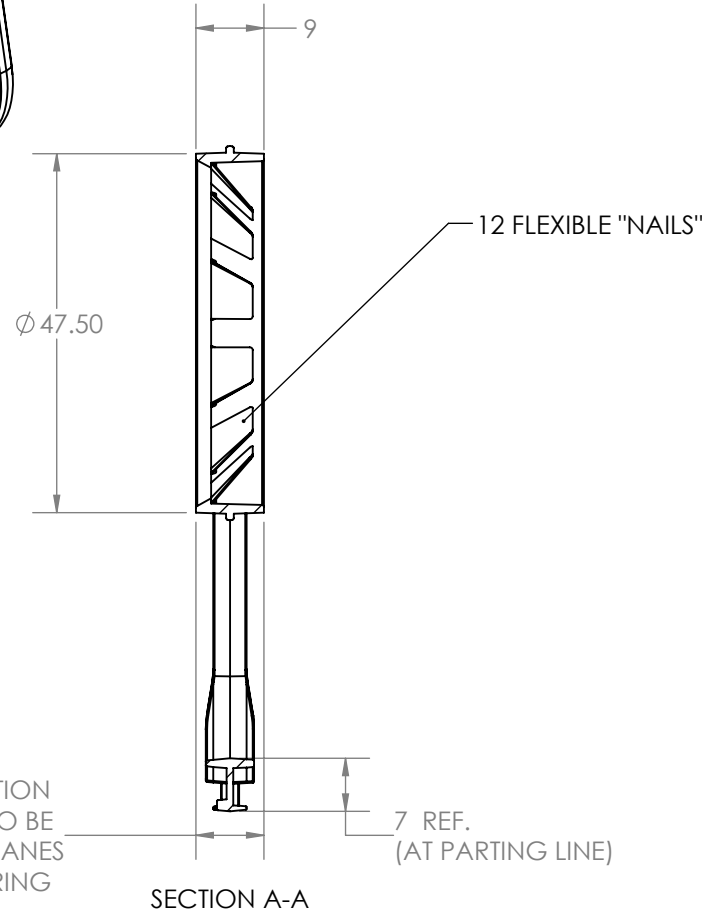
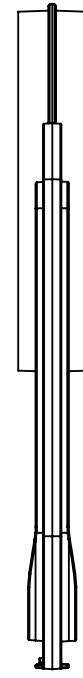
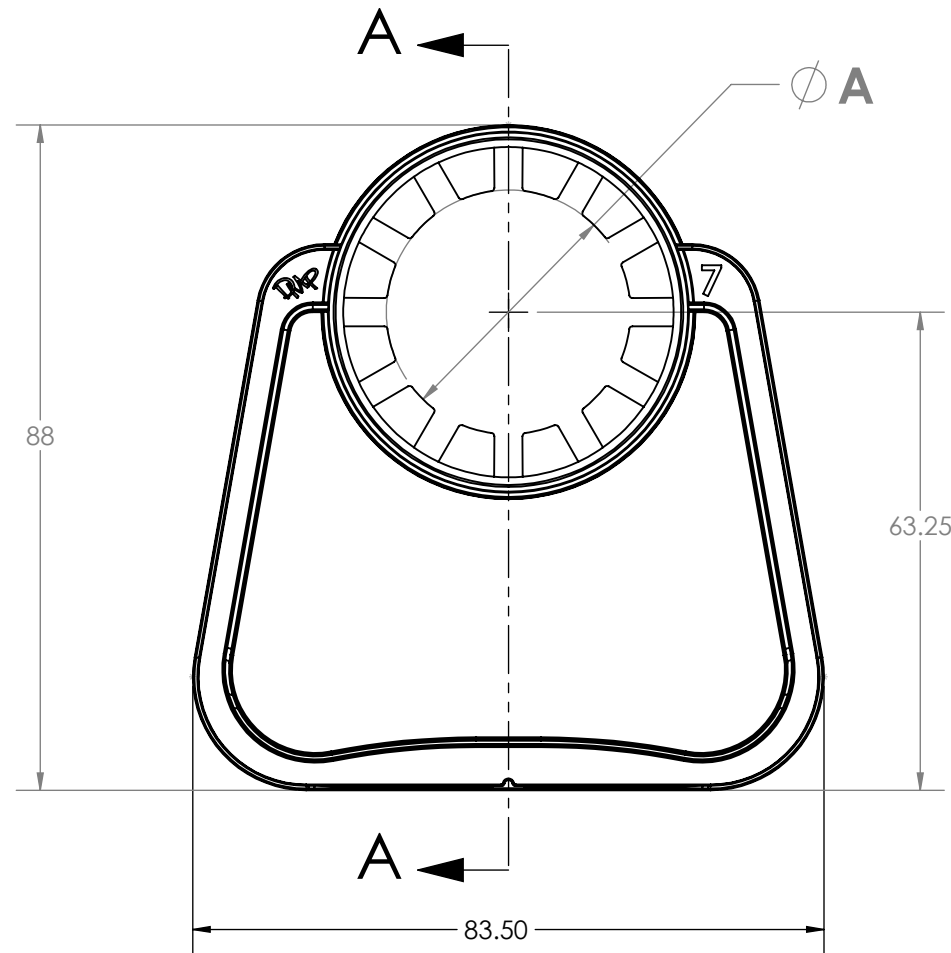
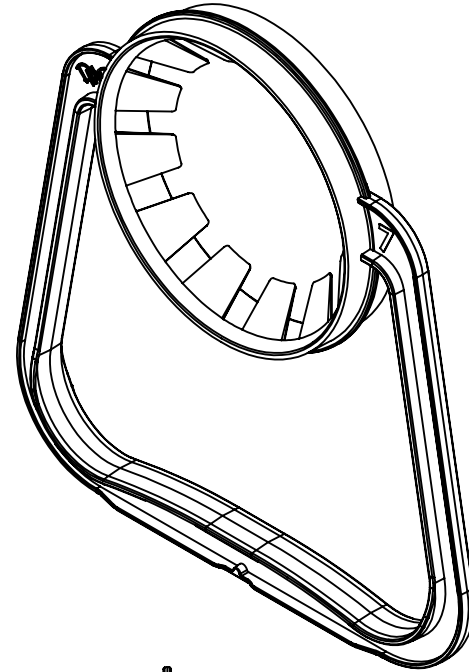
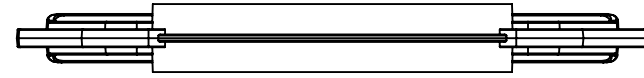

GENERAL WORKMANSHIP STANDARDS APPLY:

PARTS TO BE WELL FORMED AND FREE FROM SHORTS, STRINGS, FLASH, WARP, AND GREASE OR OTHER CONTAMINATION.

DIMENSION	>0-3	>3-6	>6-10	>10-15	>15-22	>22-30	>30-40	>40-53	>53-70	>70-98
TOLERANCE	±0.15	±0.17	±0.2	±0.24	±0.28	±0.33	±0.39	±0.47	±0.58	±0.77

Rev	Description	Date
A	RELEASE TO PRODUCTION	15JUL22
<p>UNLESS OTHERWISE SPECIFIED DIMENSIONS ARE MILLIMETERS</p> <p>CAD GENERATED DRAWING, DO NOT MANUALLY UPDATE</p> <p>APPROVALS: DRAWN DEH, CHECKED, RESP ENG, MFG ENG, QUAL ENG</p> <p>DATE: 15JUL22</p> <p>DANA MOLDED PRODUCTS, INC. 810 COMMERCE PKWY • CARPENTERSVILLE, IL 60110 847-783-1800 - voice 847-783-1801 - fax</p> <p>38mm HANDLE</p> <p>SIZE B DWG. NO. DM HANDLE-38 REV. A</p> <p>DO NOT SCALE DRAWING</p> <p>SCALE: CAD FILE: 38mm PET Handle RevA SHEET 1 OF 1</p>		

8

7

6

5

4

3

2

1

D

C

B

A